

QUIP. TYPE R300A/URR - SHIP NO.

COL. 540-7471-002

NOTICE: WHEN GOVERNMENT DRAWINGS, SPECIFICATIONS, OR OTHER DATA ARE USED FOR ANY PURPOSE OTHER THAN IN CONNECTION WITH A SPECIFICALLY PLATED DRAWING, THE UNITED STATES GOVERNMENT THEREBY ASSUMES NO RESPONSIBILITY FOR ANY INADEQUACIES, OMISSIONS, OR ERRORS THAT MAY BE MADE BY THE USER. THE USER SHALL BE RESPONSIBLE FOR OBTAINING THE LATEST EDITIONS OF ANY DRAWINGS, SPECIFICATIONS, OR OTHER DATA TO BE USED IN CONNECTION WITH THIS DRAWING. THE USER SHALL BE RESPONSIBLE FOR OBTAINING THE LATEST EDITIONS OF ANY DRAWINGS, SPECIFICATIONS, OR OTHER DATA TO BE USED IN CONNECTION WITH THIS DRAWING.

THIS DOCUMENT HAS BEEN PREPARED BY THE GOVERNMENT AND MAY BE REPRODUCED AND USED IN CONNECTION WITH ANY GOVERNMENT PROGRAM OR OPERATION.

FOR INFORMATION ONLY. CONTRACTOR MAY AT HIS OPTION DEVIATE FROM THESE PROCESS DETAILS.

SWE APPROVAL
SM PR10042-5

REVISIONS			
SYM	DESCRIPTION	DATE	APPROVAL
A1	A1 - WAS 302	9 OCT 59	42428-PC 59-A1-51 REV D PTE

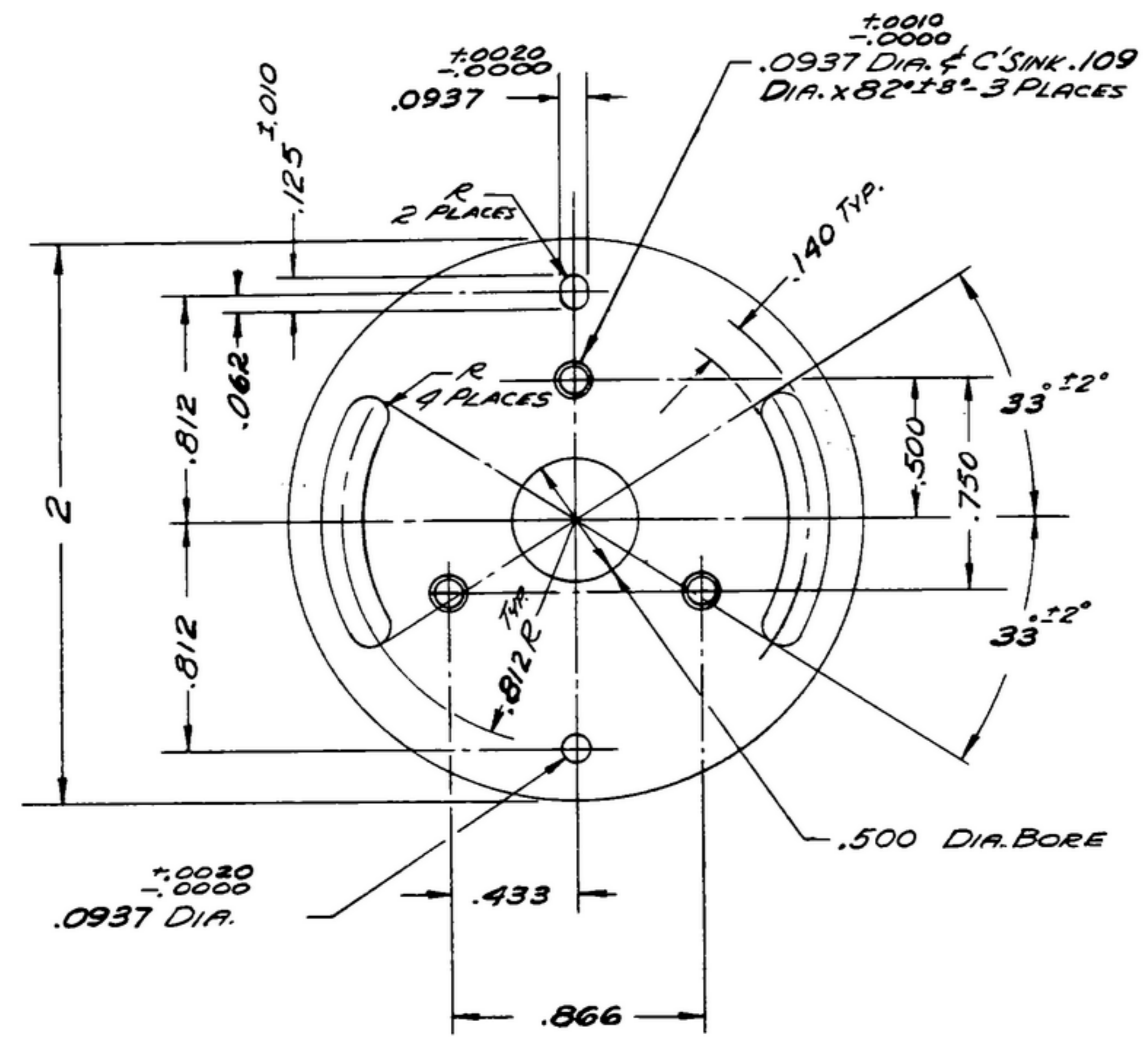

(A) CRE5, COMP 301, COND. VEHARD, PER SPEC MIL-5-5059, .0375 THICK.
FINISH: E300 PER SPEC MIL-F-14072.
* COLLINS 580-002-500

NOTES:
1. PLATE TO BE FLAT WITHIN .008 T.I.R.
2. REMOVE ALL BURRS.

COLLINS PART NO.	ITEM	QTY	PART NO.	DESCRIPTION	MATL.	DATE SPEC.
LIST OF MATERIAL						
COLLINS PART NO. 558-0259-003						

DRAWN ECS		CHECKED <i>[Signature]</i>	APPROVED	COLLINS RADIO CO. 14214-PH-51-93	PLATE-CLUTCH	DEPARTMENT OF THE ARMY SIGNAL CORPS ENGINEERING LABORATORIES FORT MONMOUTH NEW JERSEY SM-C-248910
UNLESS OTHERWISE SPECIFIED: DECIMAL DIMENSIONS INCLUDING HOLE SIZES MAY VARY ±.005 FRACTIONAL DIMENSIONS INCLUDING HOLE SIZES MAY VARY ±1/64 MACHINED ANGLES MAY VARY ±1° SHEARED ANGLES MAY VARY ±.25° BROKEN ANGLES MAY VARY ±1°			REVIEWED PME	SIGNAL CORPS		
ECCENTRICITY BETWEEN ANY DIAMETERS ON THE SAME CENTERLINE SHALL NOT EXCEED 0.10 TOTAL INDICATOR READING. ALL DIMENSIONS ARE FINISH DIMENSIONS INCLUDING APPLIED FINISH AND ARE GIVEN IN INCHES.			APPROVED HLY PME	REVIEWED PME		
APPLICATION		DATE 14 Dec 55	SCALE 2/1			